

User Manual



Battery Charger Supreme

Marine | Mobile | Land | 12 V 100 A | 3-step

whisperpower.com

For safe and optimum performance, the WP Battery Charger Supreme must be used properly. Carefully read and follow all instructions and guidelines in this manual and give special attention to the **CAUTION** and **WARNING** statements.

PLEASE KEEP THIS MANUAL FOR FUTURE REFERENCE

Disclaimer

While every precaution has been taken to ensure the accuracy of the contents of this guide, **Whisper Power BV** assumes no responsibility for errors or omissions. Note as well that specifications and product functionality may change without notice.

Important

Please be sure to read and save the entire manual before using your **WP Battery Charger Supreme**. Misuse may result in damage to the unit and/or cause harm or serious injury. Read manual in its entirety before using the unit and save manual for future reference.

Product Number:

Article Nr. 61112310 12 V 100 A (WP-BC 12/100-3)

Service Contact Information

Email: service@whisperpower.com

Phone : +31 (0) 512 571 555

Web : www.whisperpower.com

TABLE OF CONTENTS

1.	INTRODUCTION	5
2.	PRODUCT DESCRIPTION	6
3.	UNDERSTANDING THE UNIT	6
4.	INSTALLING THE CHARGER	11
5.	UNIT OPERATION	14
6.	SPECIFICATIONS	21
7.	WARRANTY	23
7.	Appendix	24
	Appendix A1	
	Appendix A2	
	Appendix A3	
	Appendix B	

1. INTRODUCTION

Thank you for purchasing the WP Battery Charger Supreme. With our state of the art, easy to use design, this product will offer you reliable service by providing a multi-stage multi-bank battery charger to charge different types of batteries you have installed in your boat, RV, vehicle or your cabin battery bank.

An innovative feature we offer is the ability to charge your main battery bank as first priority so that you may charge this main bank quickly. Another unique feature is our silent mode setting that reduces the charging current at night, thereby reducing the fan noise.

This manual will explain how to use this unit safely and effectively. Please read and follow these instructions and precautions carefully.

IMPORTANT SAFETY INFORMATION

This section contains important safety information for the WP Battery Charger Supreme. Each time, before using the unit, READ ALL instructions and cautionary markings on or provided with the unit, and all appropriate sections of this guide.

The WP Battery Charger Supreme contains no user-serviceable parts. See Warranty section for how to handle product issues.

WARNING: FIRE AND/OR CHEMICAL BURN HAZARD

Do not cover or obstruct any air vent openings and/or install in a zero-clearance compartment.

WARNING: FAILURE TO FOLLOW THESE INSTRUCTIONS CAN RESULT IN DEATH OR SERIOUS INJURY. KEEP AWAY FROM CHILDREN!

- When working with electrical equipment or lead acid batteries, have someone nearby in case of an emergency.
- Study and follow all the battery manufacturer's specific precautions when installing, using and servicing the battery connected to the charger.
- Wear eye protection and gloves.
- Avoid touching your eyes while using this unit.
- Keep fresh water and soap on hand in the event battery acid comes in contact with eyes. If this occurs, cleanse right away with soap and water for a minimum of 15 minutes and seek medical attention.
- Batteries produce explosive gases. DO NOT smoke or have an open spark or fire near the system.
- Keep unit away from moist or damp areas. Never expose unit to snow, water etc.
- Avoid dropping any metal tool or object on the battery. Doing so could create a spark or short circuit which goes through the battery or another electrical tool that may create an explosion.

WARNING: Explosion hazard!

- DO NOT use the unit in the vicinity of flammable fumes or gases (such as propane tanks or large engines).
- AVOID covering the ventilation openings. Always operate unit in an open area.

CAUTION:

- For indoor use only.
- Before charging, read the instructions.

- This appliance is not intended for use by persons (including children) with reduced physical, sensory or mental capabilities, or lack of experience and knowledge, unless they have been given supervision or instruction concerning use of the appliance by a person responsible for their safety.
- Children should be supervised to ensure that they do not play with the appliance.
- Do not charge non-rechargeable batteries because of the danger of eruption.
- During charging, batteries be placed in the ventilated area.
- The battery terminal not connected to the chassis has to be connected first.
- The other connection is to be made to the chassis, remote from the battery and fuel line. The battery charger is then to be connected to the supply mains.
- After charging, disconnect the battery charger from the supply mains. Then remove the chassis connection and then the battery connection.
- Only allow children at least 8 years old to use the battery charger. Give sufficient instruction so that the child is able to use the battery charger in a safe way and explain that it is not a toy and must not be played with. Ensure a child does not try to charge non-rechargeable batteries because of the danger of eruption.
- Examine the battery charger regularly for damage, especially the cord, plug and enclosure. If the battery charger is damaged, it must not be used until it has been repaired.

FCC/ EMC INFORMATION

This equipment has been tested and found to comply with the limits for a Class B digital device, pursuant to part 15 of the FCC and to CE directive Rules. These limits are designed to provide reasonable protection against harmful interference in a residential installation. This equipment generate, uses and can radiate radio frequency energy and, if not installed and used in accordance with the instructions, may cause harmful interference to radio communications. However, there is no guarantee that interference will not occur in a particular installation. If this equipment does cause harmful interference to radio or television reception, which can be determined by turning the equipment off and on, the user is encouraged to try to correct the interference by one or more of the following measures:

- Reorient or relocate the receiving antenna.
- Increase the separation between the equipment and the receiver.
- Connect the equipment into an outlet on a circuit different from that to which the receiver is connected.
- Consult the dealer or an experienced radio/TV technician for help.

LIMITATIONS ON USE

Do not use in connection with life support systems or other medical equipment or devices.

2. PRODUCT DESCRIPTION

The Battery Charger Supreme includes:

- Base unit: **61112310** 12 V 100 A Charger (WP-BC 12/100-3)
- Owner's manual

3. UNDERSTANDING THE UNIT

The Battery Charger Supreme is a fully automatic multistage battery charger with the ability to charge 3 separate battery banks. When first connected to an AC power source, the charger will check all three battery banks before charging commences. The charger operates on an isolated

charging design where Battery Bank 1 is separate from Battery Bank 2 and 3. Battery Bank 1 is the priority battery bank in the charging sequence and is recommended to be connected to the main (or primary house) battery bank. Battery Bank 1 can be programmed with a different charge algorithm from Banks 2 and 3.

The battery Banks 2 and 3 are connected in parallel internally (with a separation diode) and share a common charge algorithm.

During normal operation, the charger will do a full charge cycle up to the float stage on Battery Bank 1 with battery type set to either **GEL, AGM, Flooded, Lithium** (see Lithium section for limitations of use). Once the float stage is reached, the charger starts charging both Battery Banks 2 and 3 with a bulk / absorption mode (Battery Banks 2 and 3 can also be set to either **GEL, AGM, Flooded**). On completion, all the three battery banks move to float stage with a shared battery voltage determined by Battery Bank 1 settings. This setting allows the charger to remain permanently connected to mains if required. See more details in Appendix B.

Important Note: The battery Bank 1 on the charger should only be connected to the main battery bank for first priority charging. Battery Banks 2 and 3 on the charger should be connected to the other battery banks with lower priority (such as jump-start battery bank and/or AC generator battery bank used in a marine application). On single bank installations, it is recommended to only use Bank 1 on the charger.

Silent Mode (uses 'Auto' icon as indicator)

A unique feature of the WP Battery Charger Supreme is the ability to reduce fan speed at night or whenever required. This setting is manually activated via the Digital Display. Please note that charger output current will be reduced (de-rated) to about half while in Silent Mode, leading to longer recharge times. Please see "Understanding the Auto Mode Function" for more details.

Multi-Stage Charging Process:

The charger is a fully automatic "set-and-forget" design. It is designed to quickly and accurately recharge deep cycle batteries utilizing charger algorithms that help to maximize the life of specialized deep cycle batteries.

The charger features a multistage smart charging technology that enables the charger to be connected to the battery banks permanently.

As dictated by battery manufacturer's recommendations, deep cycle batteries require a multi-stage charge sequence for perfect, fast and accurate charging. This charger delivers four primary charge stages (Bulk Charge, Absorption Charge, Float, and Maintenance).

Bulk Charge 'bUL': The battery is charged at a full rated output current of the charger until the battery reaches the charging voltage, known as its absorption voltage. In this step, around 80% of the battery is recovered as fast as possible.

Absorption Charge 'AbS': With the charger voltage held steady, the remaining 20% is replaced with the charger allowing the current to drop as the battery approaches its full charge.

Float Stage 'FLO': Finally, in the float stage, the charger voltage is lowered and held at a constant and safe predetermined level. This prevents the battery from being overcharged, yet allows the charger to supply enough current to make up for the self-discharge losses of the battery while supporting any additional loads connected to the battery (such as DC lighting and refrigerators). This stage allows the charger to be used as a DC power supply.

Maintenance: This is a regular timed recharge (or return to the bulk stage). The charger switches from float stage to bulk charge after 7 days of constant operation to ensure the battery banks remain active.

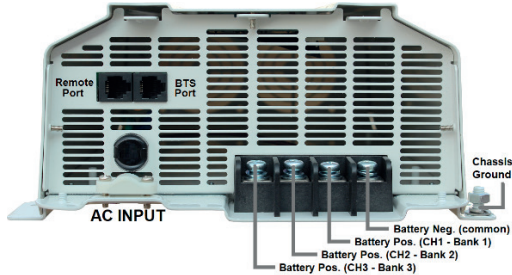
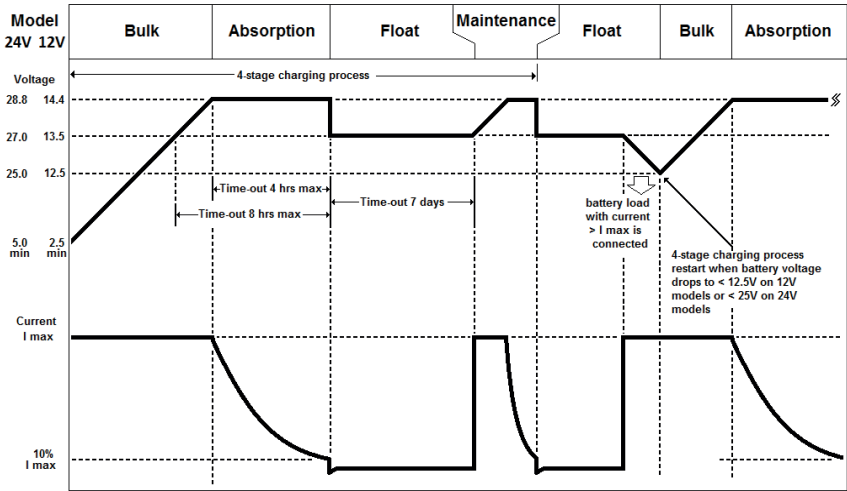

Typical wiring block diagram of the Battery Charger with 3 batteries bank:

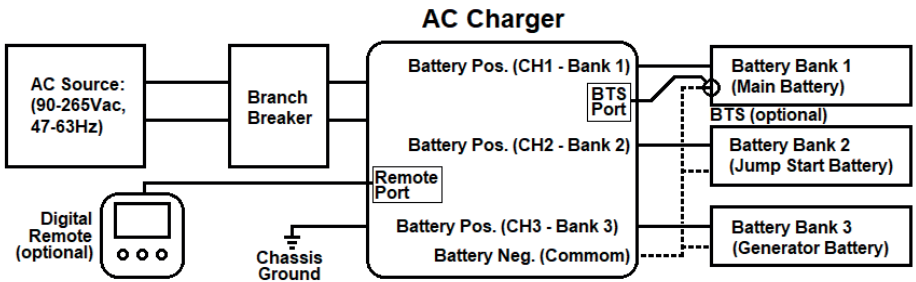

AC Source:

The charger accepts full universal input voltage (90-265Vac, 47-63Hz).

Branch Breaker:

For use on 120V AC Input source, use a 15A branch breaker to connect between the AC Source and the charger AC Input hardwire cable (Hot – black wire, Neutral – white wire, Ground – green wire).

For use on 230V AC Input source, a minimum of 8A branch breaker is required from the AC Input Source.

Battery Bank 1, 2 & 3 Setting:

There are two sets of main settings required on the charger for battery charging:

1) Battery Bank 1, Bank 2&3 Setting - for GEL, AGM, Flooded and Program battery:

- Battery type (**GEL, AGM, Flooded, Program**)
- Maximum charging current ('**h-current**' in A)
- Absorption to float stage current ('**L-current**' in A)
- Number of charging stages (Mode 2 – Bulk and Absorption stage only, Mode 3 – Bulk, Absorption, and Float stage)
- Battery temperature (Low- '**Lo**', Normal – '**nor**', High – '**hi**')

2) Battery Bank 1, Bank 2&3 Setting for Lithium battery type:

- Battery type (**Lithium**)
- Maximum charging current ('**h-current**' in A)
- Charge voltage (13.9 - 14.8V for 12 V model and 27.8 - 29.6V for 24V model)
- Charge termination current ('**L-current**' in A)

Remote Port:

The *Remote Display Port* is used for connecting an optional external Remote Display (sold separately) with identical functions to the built-in unit Digital Display.

BTS Port (Battery Temperature Sensor Port):

The Battery Temperature Sensor BTS (sold separately) is available and is used to connect to the negative terminals of Battery Bank 1. When using on **GEL, AGM, or Flooded** battery, it measures the battery temperature and will make small adjustments to the battery charging voltage for better battery charging performance. When using on **Lithium** battery, it will not make any adjustment to the battery charging voltage but it is used to terminate the battery charging process when the battery temperature drops to below 0 C or higher than 60C and the charging process will resume when it senses the battery temperature return to the normal operation temperature range. As Battery Bank 1 is designed for charging the main battery bank on the system, it is highly recommended to have the battery temperature sensor connected to Battery Bank 1. No setting is required for the temperature sensor; it is recognized automatically when it is plugged into the unit.

- If the temperature sensor is not used, you can also manually set the temperature to Low – '**Lo**', Normal – '**nor**', or High – '**hi**' to reflect the environmental temperature for a better charging effect. Manufacturing default setting is set to 'Normal' temperature. See more details on **Understanding the Battery Temperature** in Section 5.

CAUTION: RISK OF BATTERY DAMAGE. If the temperature sensor is not being used, never set the battery temperature lower than the actual temperature. This may **overcharge and damage** the battery.

- A WhisperPower Temperature Sensor (sold separately) is available and is used to attach to one of the batteries. It measures the battery temperature and will make small adjustments to the battery charging voltage for better battery charging performance. As Bank 1 is designed for charging the main battery bank on the system, it is highly recommended to have the battery temperature sensor attached to Bank 1 battery bank.

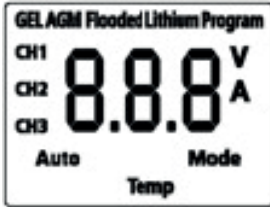

Digital Display:

- ‘CH1’, ‘CH2’ and ‘CH3’ represent Battery Bank 1, 2 and 3 respectively. With ‘CH1’ turned on, the numerical value on the display shows individual battery information like battery voltage in ‘V’ or charging current in ‘A’. ‘CH 2’ and ‘CH 3’ will always turn on together, the numerical value on the display shows the total charging current in ‘A’
- ‘GEL’, ‘AGM’, ‘Flooded’, ‘Lithium’ and ‘Program’ represent different battery types setting.
- ‘Auto’ indicates Silent Mode is activated
- ‘Mode’ only turns on during the setting of charging stage
 Mode 2 - (2 stages: Bulk and Absorption stage)
 Mode 3 - (3 stages: Bulk, Absorption and Float stage)
- ‘Temp’ only turns on when manually setting of battery temperature.

Battery Charging Voltage:

Voltage default settings			
Battery Type	Absorption	Float	Equalization
GEL	14.4 V	13.7 V	N.A.
AGM	14.7 V	13.6 V	N.A.
Flooded	14.4 V	13.3 V	15.5 V (See Note 1)
Lithium	Constant 13.9 – 14.8 V (0.1V Step, See Note 2)		N.A
Program	13.8 – 14.8 V	13.0 – 13.8 V	N.A

Note 1: Equalization setting can only be used on flooded battery type selection only.

See more details on the **Procedure to Equalize the Flooded Battery** section

Note 2: Charger will terminate charging when charging current drops below the set termination value.

Battery Bank Size Recommendation:

The battery charging current rating is based on the battery size. When charging **GEL, AGM** and **Flooded** batteries, each battery bank should meet the minimum Ah rating as shown. If a smaller size battery bank is used, set the current rating to a lower value to match with the battery bank size. Normally, the maximum charger current rating is based on half the battery bank capacity.

Capacity I _{max} settings					
Current Setting (A)	100	60	40	20	10
Minimum Battery Capacity (Ah)	200	120	80	40	20

When charging Lithium battery, consults the Lithium battery manufacturer for maximum allowable charging current.

Power Supply

The charger can also be set to power supply mode (**Program** setting). With this setting, the charger will only provide constant voltage and current to CH 1, while CH 2 & 3 (Bank 2 & 3) are disabled. No DC voltage or current will be supplied to Ch 2 & 3 even if battery banks are connected to the two channels. The charger will act as a constant voltage power supply with user selected supply voltage and maximum current.

4. INSTALLING THE CHARGER

WARNING: Whisper Power BV recommends all wiring to be done by a certified technician or electrician to ensure adherence to the applicable electrical safety wiring regulations and installation codes. Failure to follow these instructions can damage the unit and could also result in personal injury or loss of life.

CAUTION: Before beginning your unit installation, please consider the following:

- The unit should be used or stored in an indoor area away from direct sunlight, heat, moisture or conductive contaminants.
- When placing the unit, allow a minimum of three inches of space around the unit for optimal ventilation.

Note: The WP Battery Charger Supreme is designed to be permanently mounted.

Mounting the Charger:

- Choose an appropriate mounting location.
- For installing in an indoor location, the unit can be mounted in any direction.
- For installing in boat or marine environment, the unit can be mounted horizontally and vertically (AC and DC panel facing downwards) only.
- Use the mounting template below to mark the positions of the mounting screws.
- Drill the 4 mounting holes and place the Charger in position and fasten the unit to the mounting surface. See mounting location as below.

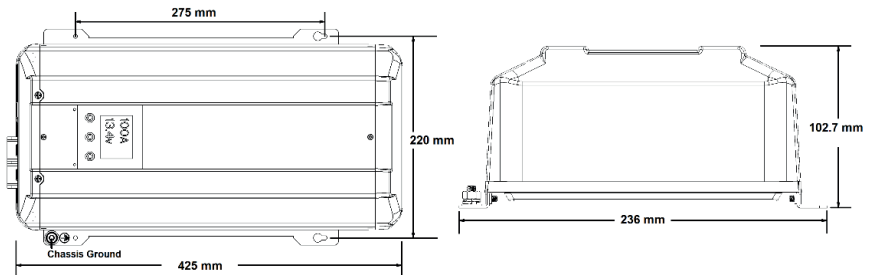

Chassis Grounding Connection:

DANGER: The unit chassis has to be grounded properly. Never operate the Charger without proper grounding. Failure to do so will result in death or serious injury. Ground connection to the charger must comply with all local and application-specific codes and ordinances.

- Connect the unit's chassis ground to the common ground point through the ground stud located near one of the unit mounting slots. See image in Section 3.

DC Output Wiring:

WARNING: The DC wiring used must be of appropriate size. An individual over-current protection device usually within 7 inches (17.8cm) of each battery bank is required. A DC disconnect switch is also recommended. Both devices must be rated for DC voltage and current and be rated to withstand the short circuit current available from the connected battery bank. Both devices must match with the size of the DC wiring.

Recommended Cable Length, Size and Required Fuse Size:

Wire Length	Wire Size (AWG/mm ²) - Fuse Size (A)
5' (1.5 m)	#2 / 12mm ²
7.5' (2.2m)	#1/0 / 16mm ²
10' (3m)	#2/0 / 35mm ²

- Remove the DC compartment cover by removing the two screws located on the top surface of the unit near the AC wiring compartment.
- Keep the connection between the battery and the charger as short as possible.
- Connect one end of the positive wire (red wire) to the Bank_1 of charger positive terminal with torque 4.0 ~ 5.0 N-m (35 ~ 45 lb-in) and the other end to the over current protection device, then the DC disconnect device. Do not over tighten as this may result in damage to the charger.
- Connect another wire from the DC disconnect device to the battery bank.
- For systems with multi-battery banks: Follow the same instruction as on Bank_1 and connect to Bank 2 & 3 accordingly.
- Prepare the negative wire (black wire) and connect to the negative terminal of the charger. Connect the other end of the negative wire to all the negative terminals of the battery bank(s).
- Place the DC Compartment cover back to the original position and secure the cover using the two screws provided.

AC Input Wiring:

WARNING: The AC wiring must be of appropriate size, and it must be protected by an appropriate branch breaker (not provided) connected between the AC source and the Charger.

A three core color coded #14 AWG wire (L, N and GND) with a rated minimum of 75°C wire mains cord and EU plug is provided with the charger.

Confirm that the strain relief at the charger inlet position is secured.

Connect AC source by plugging in to EU Schuco socket.

Optional Remote Display Connection:

(see more details in the instructions provided with the Remote Display)

For use with one charger unit:

- To install the optional Remote Display in a specific location, the 6 pin “rollover” RJ12 cable (maximum length 25 ft.) provided with the Remote Display, is required.
- Install the rollover RJ12 cable in your desired location.
- Connect one end of the RJ12 cable to the Remote Display Port and the other end of the cable to the COM_1 port on the Remote Display Panel. (Do not use COM_2 on the Remote Display)
- The Remote Display is now ready for use.
- The RJ12 cable below may come with a ferrite bead at one edge. If so, we suggest connecting that edge toward the unit.

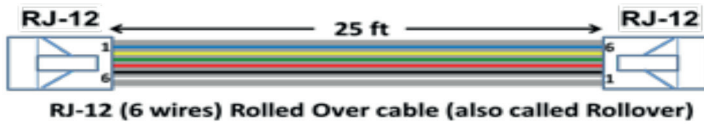

For use with two charger units connected in parallel (same model number only):

- When having two chargers in parallel, the total current to the batteries is the sum of the ones supplied by each one of the chargers. You can see that total current (the sum) as a unique reading, by using the optional Remote Display. It also synchronizes both chargers in order to keep the same charging stage and distribute their charging currents almost equally, so that one charger will not work more than the other one.
- When using the optional Remote Display for two units in parallel, they have to be the same model number (i.e. two WP-BC 12/100-3 chargers or two AC2450 chargers). Therefore, the total charging current to the battery banks is doubled.
- In this case, an additional (not provided) 6-pin “rollover” RJ12 cable (maximum length 25 ft.) is required for a total of two cables.
- Install the two rollover RJ12 cables in your desired location.
- For the first RJ12 rollover cable, connect one end to the Remote Display Port of Charger_1 and the other end to Remote Display Panel COM_1 Port.
- For the second RJ12 rollover cable, connect one end to the Remote Display Port of Charger_2 and the other end to Remote Display Panel COM_2 Port.
- The Remote Display is now ready for use.

Note 1: With AC Input power available, both Digital Displays will show ‘CON’ indicating the two chargers are connected in parallel. The ‘INFO’, ‘NEXT’ and ‘SET’ push buttons on both chargers are disabled. Use the Remote Display for charger unit setting. With no AC Input available, pressing and holding the ‘INFO’ button on Charger_1 for at least 3 sec. will show the battery voltage of Bank 1, 2, 3 and then follow with charger firmware revision (e.g. “u1.0”).

Note 2: The combined chargers setting is based on the original setting on Charger_1. To readjust the combined charger setting, it has to be done through the Remote Display. Before connecting the batteries to the chargers, Battery Bank 1 of Charger_1 has to connect to Battery Bank 1 of Charger_2. Battery Bank 2 of Charger_1 has to connect to Battery Bank 2 of Charger_2 and Battery Bank 3 of Charger_1 has to connect to Battery Bank 3 of Charger 2. The Common Ground of both chargers has to be connected together. Damage to both chargers may occur if the above connections are not followed.

Tips: During installation or unit setting, it is recommended to pre-set the desired charger setting on Charger_1 first before connecting the second RJ12 cable to Charger_2, as once Charger_2 is connected, all the three push buttons on the charger are disabled and the display will only show ‘CON’ and the setting can only be adjusted by using the Remote Panel.

Optional Battery Temperature Sensor (BTS) Connection:

For single charger operation:

- To install the temperature sensor, simply connect the RJ12 plug from the sensor to the corresponding jack of the Temperature Sensor Port on the charger
- On the Temperature Sensor end, simply connect the ring terminal (lug) to the negative

terminal of the chosen battery bank. As Battery Bank 1 is for the main battery bank charging, it is highly recommended to connect the Temperature Sensor to Battery Bank 1 when in use.

For parallel charger operation (by using two units of the same model):

- Two batteries Temperature Sensors are required.
- Connect the RJ12 plug from the Temperature Sensor 1 / 2 to the corresponding Temperature Sensor Port jack on charger 1 / 2 respectively.
- On both Temperature Sensor ends, simply connect the ring terminals (lugs) to the negative terminal of the main battery bank.

Test the Charger Connection:

- Switch AC branch breaker switch to ON.
- The display will turn on. Pressing the 'Info' key will toggle the display to show the factory default setting. The charger is now ready to use.

5. UNIT OPERATION

Understanding the Charging Mechanism

- The charger is a three-bank battery charger that is capable of charging a maximum of three battery banks.
- The charger is designed to have Bank 1 charge the main battery bank. Always use Bank 1 first when connected to a single battery bank.
- At start, if the charger senses Battery Bank 2 and 3 have battery connected and the battery voltage is greater than 11V, the charger will then concentrate on fully charging Battery Bank 1 first until it reaches float stage. It will then switch to charge Battery Bank 2 and 3.

Or:

- If the charger senses either Battery Bank 2 or 3 have battery connected and the battery voltage is below 11V, it will cycle to charge Bank 1 for 15 minutes then Bank 2 and 3 together for 15 minutes. When the charger senses both Bank 2 and 3 reach 13V, it will then concentrate on charging Bank 1 until it reaches the float stage. After that, it will then concentrate on recharging Bank 2 and 3 (together) to float stage.
- Once all three banks have reached the float stage, the charger will adjust the charging voltage to the preset float voltage of the battery bank 1, and all three banks will be connected in parallel for float stage charging. During the float stage charging stage, each battery bank is isolated by an internal separation diode.
- In float stage, see the below chart for the maximum allowable current draw:

	WP-BC 12/100-3
Maximum Float Current	60 A

For charging GEL, AGM, Flooded batteries:

- The charger can be set to 'Mode 2', 2 stage charging (Bulk and Absorption stage charging only- no float stage) or 'Mode 3', 3 stage charging – (Bulk, Absorption, and Float stage charging).
- Each battery bank can have its own maximum charging current and absorption-to-float mode current settings.

For charging Lithium batteries:

WARNING: FIRE HAZARD! When using the Lithium mode to set the battery Charging parameters, please consult the battery manufacturer on all voltage and current settings. Using wrong setting to charge the Lithium battery may overcharge and damage the battery, resulting in battery explosion and fire.

Charging the Lithium battery requires the user to set the charger termination current. The charging process will terminate when the charging current drops to the set termination current.

For using Program mode for charging batteries:

WARNING: FIRE HAZARD! When using the Program mode to set the battery charging parameters, please consult the battery manufacturer on all voltage and current settings. Using a wrong setting to charge the battery may overcharge and damage the battery, resulting in battery explosion and fire.

The following parameters can be programmed in the **Program** mode:

- Bulk/Absorption Voltage (13.8 – 14.8V)
- Float Voltage (13.0 – 13.8V)
- Mode 2 or Mode 3

Note: When program mode is used, the Battery Temperature Functions are disabled.

Understanding the Digital Display and the Function Keys during Normal Operation:

During normal operation, the display shows the related channel's battery voltage, charging current, and charging stage ('bUL' – Bulk stage, 'AbS' – Absorption stage, 'FUL' – Float stage) alternately. When all channels reach float stage, the display starts showing 'FUL' indicating that all the batteries connected are fully charged.

During the equalization operation on a flooded battery, the numerical section on the display shows a flashing 'Eq' indicating the equalization process is in progress and does *not* show the battery voltage or the charging current.

Understanding the Digital Display Function with no AC Input:

With the unit already turned off (by disconnecting its AC-Input power) and the display completely in blank, press and hold the 'INFO' key for at least 3 seconds until you see something on the display. The display will show the voltage on each battery bank (channel) alternately (one at a time), as well as the charger software revisions (e.g. "u1.5" or higher). If you read "0.6V" or "0.7V" it would mean that there is not any battery connected to that battery bank terminal.

This feature is useful to know what battery banks (channels) are actually connected to the unit.

Understanding the Function Key 'INFO', 'NEXT' and 'SET' during Charger Setting:



'INFO': Press and hold the key for longer than 3 seconds to enter the charger setting mode and show function setting. Once the new setting is done, press 'INFO' again to exit the charger setting mode.

'NEXT': Press the key once to keep or save the chosen setting and change the display to show the next menu to continue other settings.

Note: The selected setting will quickly flash 3 times to acknowledge the setting.

'SET': Press the key to view other available settings or Press and hold the key for 3 seconds to activate or deactivate '**Silent Mode**' – '**Auto**' icon to show on display (see more details on Page 5).

Please note: on later editions of the remote display, 'SET' is replaced by 'ESC'.

Understanding the Three-Stage (Mode 3) Charging:

The Three-Stage Charging (Mode 3) has a Bulk, then Absorption, and then Float sequence. During the Bulk stage, the battery accepts the maximum constant current from the charger. In the Absorption stage, the battery voltage is held to constant voltage and the charging current will slowly reduce. In Float stage, the charger continuously produces lower constant float voltage to fully top up and maintain the battery in a fully charged stage.

The charger will automatically restart the full charging cycle if it senses any one of the battery banks is

discharged to lower than 12.5V or after seven days in float stage to refresh the battery banks.

Understanding the Two-Stage (Mode 2) Charging:

The Two-Stage charging is similar to the Three-Stage charging except there is no float stage after the absorption stage. The charger will terminate the battery charging after Absorption.

The charger will automatically restart the full charging cycle if it senses any one of the battery banks is discharged to lower than 12.5V, or after seven days since the last Absorption stage, to refresh the battery banks.

Understanding the Battery Temperature Functions:

The optional Battery Temperature Sensor (Part Number 60201202) is highly recommended with the charger to protect your battery and provide better charging voltage accuracy. It is recommended to be installed on the main battery bank - Bank 1.

The sensor senses the battery temperature and will override the manual temperature setting and make small adjustments to the charging voltage.

Battery Temperature	Battery Charging Voltage Adjustment from 25 °C normal setting	
	Flooded and GEL type	AGM type
< 25 °C	+ 0.027 V /°C	+ 0.021 V /°C
25 °C	0 V	0 V
> 25 °C	- 0.027 V /°C	- 0.021 V /°C

When the battery sensor is not in use, you can also manually set the battery temperature. There are three manual battery temperature settings on the unit ('Lo', 'nor' and 'hi'). See below for voltage adjustments for temperature compensation.

Temperature Setting	Recommended for Battery Temperature	Battery Type	Voltage adjustment from 25°C normal setting
Low (Lo)	<5°C (41°F)	GEL, Flooded	+ 0.675 V
		AGM	+ 0.525 V
Normal (nor)	>5°C and <30°C (>41°F and <86°F)	GEL, Flooded	0 V
		AGM	0 V
High (HI)	>30°C (86°F)	GEL, Flooded	- 0.27 V
		AGM	- 0.21 V

Procedure to set or view the charger setting:

Follow the procedure or sequence in Appendix A1-A3 to set or view the charger setting.

For GEL, AGM, Flooded or Program battery type:

Parameters below are required for setting:

- Battery type (GEL, AGM, Flooded or Program)
- Bulk/Absorption and Float voltage setting for Program battery type only. (Default values 14.4/13.5V)
- Maximum Current setting and Absorption to float stage current setting (see table below)
- Charging stage (Mode 3: 3-stages, Mode 2: 2-stages)
- Battery temperature for GEL, AGM, and Flooded battery type only

The following table shows the maximum available charging current and its related available Absorption to Float stage current.

Model	Maximum Current Setting (CH1)	Absorption to Float Stage Current Setting (CH1)	Maximum Current Setting (CH2/3)	Absorption to Float Stage Current Setting (CH2/3)
WP-BC 12/100-3	* 100 A	* 4A / 8A / 12A	60 A	3 A / 6 A / 12 A
	60 A	3 A / 6 A / 12 A	40 A	2 A / 4 A / 8 A
	40 A	2 A / 4 A / 8 A	20 A	1 A / 2 A / 4 A
	20 A	1 A / 2 A / 4 A	10 A	0.5 A / 1.0 A / 2.0 A

Note: * Recommended setting (Factory Default Setting)

For **Lithium battery type**:

Parameters below are required for setting:

- Charging Voltage (13.9 - 14.8V)
- Maximum Charging Current and Termination Charging Current (current to define when the charging process will terminate)

Model	Maximum Current Setting (CH1)	Absorption to Float Stage Current Setting (CH1)	Maximum Current Setting (CH2/3)	Termination Charging Current
WP-BC 12/100-3	* 100 A	* 4A / 8A / 12A	60 A	3 A / 6 A / 12 A
	60 A	3 A / 6 A / 12 A	40 A	2 A / 4 A / 8 A
	40 A	2 A / 4 A / 8 A	20 A	1 A / 2 A / 4 A
	20 A	1 A / 2 A / 4 A	10 A	0.5 A / 1 A / 2 A

Procedure to Equalize Flooded Battery:

DANGER: Explosion Hazard. The battery generates explosive gasses during equalization. Follow all the battery safety precautions listed in the manual.

DANGER: Explosion Hazard and Risk of Battery damage. When using the equalization mode, the user has to be sure the battery connected to the channel is a flooded battery type. Equalizing a non-flooded battery may overcharge it and cause the battery to explode.

CAUTION: Risk of Battery and Equipment damage. Only a Flooded lead-acid battery can be equalized. Consult your battery manufacturer or read the battery manual when you try to equalize your batteries. Disconnect any DC load connected to the battery, as during equalize mode, the charger will produce 15.5V to the batteries. You must monitor the battery specific gravity throughout the equalization process to determine the end of the equalizing cycle.

Before setting the equalization mode on the specific channel, please be sure the battery connected to the specific channel is a flooded battery type. When the battery equalization process started, the charger will automatically fully charge the selected channel first and follows with 1 hour of 15.5V equalization process. Consult or follow the instruction as provided by the battery

manufacturer on how to check the battery electrolyte level and or refill with distilled or deionized water during the 1 hour's equalization period. All cells should have similar electrolyte levels. If distilled or deionized water is added, batteries must undergo a complete charge cycle.

The charger cannot determine when to terminate the equalization of the battery. A one-hour timeout is set as a safety feature by requiring the user to continually re-activate it as necessary after checking the batteries manually. During the equalization mode, the other two banks are disabled.

Understanding the Silent Mode Function

The charger also comes with another unique '**Silent**' Mode function that will change the internal fan operation.

Mode Operation	Fan Operation	WP-BC 12/100-3
Normal Mode	Full Speed	100 / 60 / 40 / 20 / 10 (A)
Silent 'Auto' Mode	Low speed or Fan OFF	50 / 50 / 40 / 20 / 10 (A)

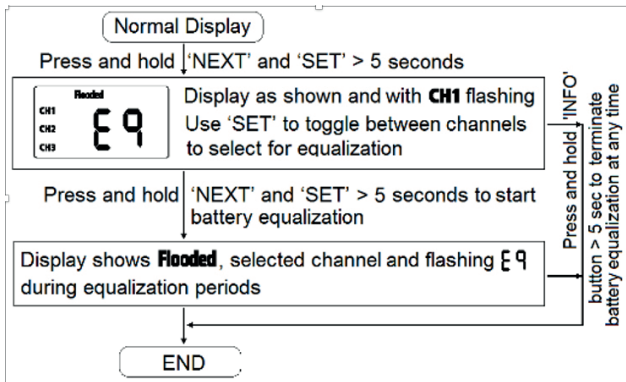

Tips: Use this function during nighttime or when a quiet environment is needed. Please also note that the charging time will increase in this mode because the charger is not running at maximum power (it is de-rated).

This function can switch to **ON** or **OFF** at any time during the charging period. To set this function, press and hold '**SET**' key for 3 seconds to execute the '**Silent**' Mode. The '**Auto**' icon will show on the display. To turn this function off, press and hold the '**SET**' function for 3 seconds to turn off '**Silent**' Mode. The '**Auto**' icon on the display will turn off and the charger current and the fan speed will return to normal. Also; the charger will automatically depart from **Silent** Mode after 12 hours from being set.

Understanding the Protection Features

Derating the Charging Current: When the charger senses the environmental temperature is above 50°C, the maximum charger current will de-rate to 1/2 of the value (A02 warning code will display). The charger will recover automatically back to the maximum charging current when the environmental temperature drops to below 45°C.

Over Temperature Shutdown: When the charger senses the environmental temperature is above 60°C, the charger will shut down. It will recover automatically when the environmental temperature drops to below 45°C.

Battery Reverse Polarity: When a reverse polarity is connected to the battery bank, Fault Code E03 on display will appear. In some case, the user replaceable DC fuse located near the DC Output terminals may blow and Error code E08 will display.

AC Input Voltage Protection: The charger will shut down when it senses the AC input voltage is outside of the operating range. A fault code will display. The charger will recover automatically when it senses the AC input voltage has returned to the normal operation range.

Disconnecting the Battery Bank: To avoid any spark on the battery terminal, always disconnect AC Input before removing or disconnecting the battery.

BTS Shutdown (with optional BTS in use): To avoid any battery damage especially when a Lithium battery is used, the charging cycle will be terminated when the optional BTS senses the battery temperature is above 60 C or below 0C.

Charging Dead Batteries

The charger is designed to charge batteries with the voltages on their terminals greater than 3Vdc. For lower voltages, the batteries can be temporarily and partially charged using the charger's "Program" ("Power Supply") setting, before returning to the proper battery type setting.

Reinitiating the charging cycle and the battery connection status manually

When all the channels in use (the ones with battery connected) are already in 'Floating' stage, with the display showing "FUL", you can reinitiate manually and immediately the charging algorithm from the Bulk stage. To do so, you need to reset the unit by disconnecting the AC power that feeds the charger, and then, the battery positive on CH1 as well. Wait until the display goes off, and then reconnect both the CH1 positive and the AC-Input power.

Understanding the Error Codes

Error codes will be shown on the display when either an internal fault such as *high internal temperature* or external fault like *AC input voltage out of range* is detected. The unit will shut down.

Code	Condition	Corrective Action
A01	Temperature Sensor (BTS) is defective.	Check and or replace the sensor.
E01	Unit shutdown due to low AC Input (< 85 +/- 5Vac)	Check AC input source. The unit will automatically recover when the AC Input voltage return to > 108 +/-5Vac
E02	Unit shutdown due to high AC Input (>270 +/- 5Vac)	Check AC input source. The unit will automatically recover when the AC Input voltage returns to < 260 +/-5Vac
E03	Battery is connected backwards	Check all battery connections
E04	Charger Internal temperature is too high and it has to shut down. The unit will automatically recover when the unit cools down.	The ventilation of the unit is blocked or the environmental temperature is high. Reduce charging current or improve the ventilation near the unit.
E05	Not used.	
E06	<p><i>For non- Lithium Battery type setting:</i> High battery temperature >70 °C (158°F) is sensed by the BTS when installed. The unit will shut down. The unit will automatically recover when the battery temperature has reduced to 60°C (140°F).</p> <p><i>For Lithium battery type setting:</i> High battery temperature >60 °C (140°F) is sensed by the BTS when installed. The unit will shut down. The unit will automatically recover when the battery temperature has reduced to 55°C (131°F).</p>	Check the battery, charger setting, and its environment.
E07	<p><i>For non- Lithium Battery type setting:</i> Low battery temperature < -25°C (-13°F) is sensed by the BTS when installed. The unit will shut down. The unit will automatically recover when battery temperature reaches -20°C (-4°F).</p> <p><i>For Lithium Battery type setting:</i> Low battery temperature < 0°C (32°F) is sensed by the BTS when installed. The unit will shut down. The unit will automatically recover when battery temperature reaches 5°C (41°F).</p>	It is not recommended to charge the battery at low temperatures.
E08	DC Output fuses are blown.	Check battery connection and replace the fuse with the same type and rating.
E09	Unit shutdown due to high battery voltage (> 17 Vdc). The unit will automatically recover when battery Voltage is reduced to <16Vdc.	Check battery and charger settings. Check also if there is any other DC supply connected to the battery banks.

6. SPECIFICATIONS

WP-BC 12/100-3	
Charger Output:	
Output Current (Maximum)	100 A
Output Voltage Range:	
Charge	13.8 – 14.8 V
Float	13.0 - 13.8 V
Equalize (Flooded Battery)	15.5 V
Charging Control	Three stages (Bulk/Absorption/Float) Two stages (Bulk/Absorption)
DC Output Bank	Three (CH1, CH2, CH3)
Selectable Battery Type	Gel, AGM, Flooded, Lithium, Program
Parasitic Current	< 2 mA
Charger Input:	
AC Input Voltage (Nominal)	100, 120, 220, 230, 240 VAC
AC Input Operating Range	90 - 265 VAC
AC Input Frequency Range	47 - 63 Hz
Power Consumption (Full Load)	1750W
Power Factor Correction	Yes
Charger Efficiency	> 82%
Protection and Features:	
Reverse Battery	Yes, unit shutdown
Over Charge	Yes, unit shutdown
Over Temperature	Yes, unit de-rated and shutdown
Output Short Circuit	Yes, unit shutdown
Cooling	Forced air ventilation
Temperature Setting	Hot, Normal, Cold (with no sensor connected)
Battery Temperature Sensor Port	RJ12 (for use with optional Battery Temperature Sensor)
Remote Display Port	RJ12 (for use with optional Remote Display Panel)
Display:	
LCD Display (with back lighting)	Charging status, Battery Voltage
Warning and Fault Code	A01, E01-09
AC Input and DC Output Connection:	
AC Input Connection	Hardwire or AC with EU, UK, AZ plug
DC Output Connection (POS)	Heavy Duty Screw Terminal (3 banks)
DC Output Grounding (NEG)	Heavy Duty Common Ground Screw Terminal
Environmental and Operating Temperature:	
Storage Range	-40° to 70° C (-40° to 158° F)
Operating Range	-20° to 60° C (-4° to 140° F)
Humidity	5-95%, RH non-condensing
Ingress Protection	IP32

Based Unit Weight and Dimensions:	
Weight	
Dimension	236 x 425 x 102.7 mm (9.3 x 16.7 x 4')
Regulatory Compliance:	
Standards/Safety (North America)	Approved to UL 1236 including the marine supplement UL 1564 CSA C22.2 107.2-01
Standards/Safety (European Union)	CE marked for the low voltage directive 2006-95-EC Complying with EN60335-2-29 battery chargers Approved to IEC60529:2001, IP32 ingress protection level
Standards/EMC (North America)	Class B according to FCC part15B and ANSI C63.4
Standards/EMC (European Union)	CE marked for the EMC directive 2004-108-EC Complying with EN55014-1, EN55014-2, EN61000-3-2, and EN61000-3-3 (as equivalent IEC standards series)

Note: Specifications are subject to change without notice.

7. WARRANTY

Five Year Limited Warranty

The limited warranty program is the only one that applies to this unit, and it sets forth all the responsibilities of Whisper Power BV. There is no other warranty, other than those described herein. Any implied warranty of merchantability of fitness for a particular purpose on this unit is limited in duration to the duration of this warranty.

This unit is warranted, to the original purchaser only, to be free of defects in materials and workmanship for one year from the date of purchase without additional charge. The warranty does not extend to subsequent purchasers or users.

Manufacturer will not be responsible for any amount of damage in excess of the retail purchase price of the unit under any circumstances. Incidental and consequential damages are specifically excluded from coverage under this warranty.

This unit is not intended for commercial use. This warranty does not apply to damage to units from misuse or incorrect installation/connection. Misuse includes wiring or connecting to improper polarity power sources.

RETURN/REPAIR POLICY:

If you are experiencing any problems with your unit, please contact our customer service department at service@whisperpower.com or phone +31 (0) 512 571 555 before returning product to the retail store. After speaking to a customer service representative, if products are deemed non-working or malfunctioning, the product may be returned to the purchasing store within 30 days of original purchase. Any defective unit that is returned to manufacturer within 30 days of the date of purchase will be replaced free of charge.

If such a unit is returned more than 30 days but less than one year from the purchase date, manufacturer will repair the unit or, at its option, replace it, free of charge. If the unit is repaired, new or reconditioned replacement parts may be used, at manufacturer's option.

A unit may be replaced with a new or reconditioned unit of the same or comparable design. The repaired or replaced unit will then be warranted under these terms for the remainder of the warranty period. The customer is responsible for the shipping charges on all returned items.

LIMITATIONS:

This warranty does not cover accessories, such as adapters and batteries, damage or defects result from normal wear and tear (including chips, scratches, abrasions, discoloration or fading due to usage or exposure to sunlight), accidents, damage during shipping to our service facility, alterations, unauthorized use or repair, neglect, misuse, abuse, failure to follow instructions for care and maintenance, fire and flood.

If your problem is not covered by his warranty, contact our customer service department at service@whisperpower.com or phone +31 (0) 512 571 555 for general information if applicable.

Appendix A1

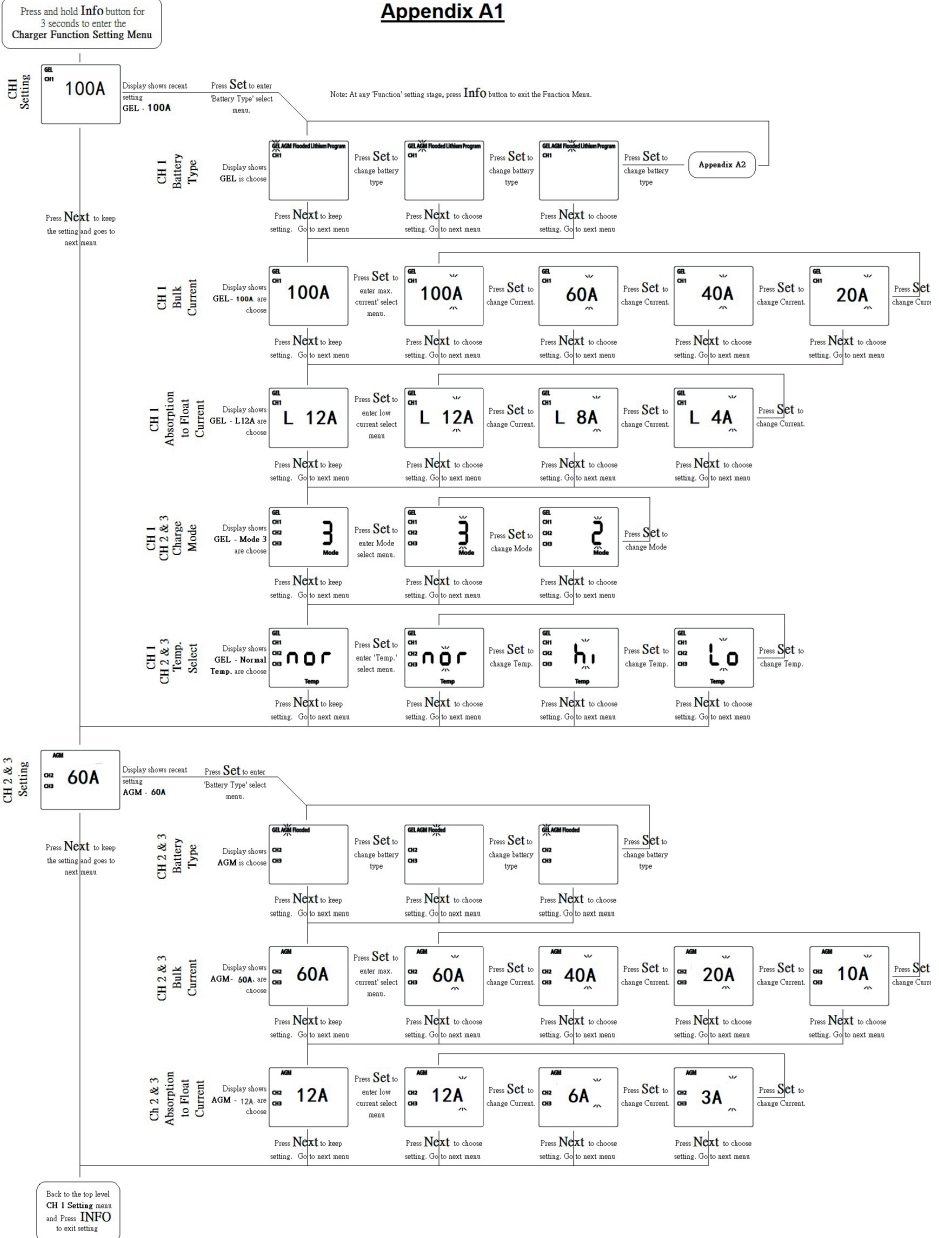

Appendix A2

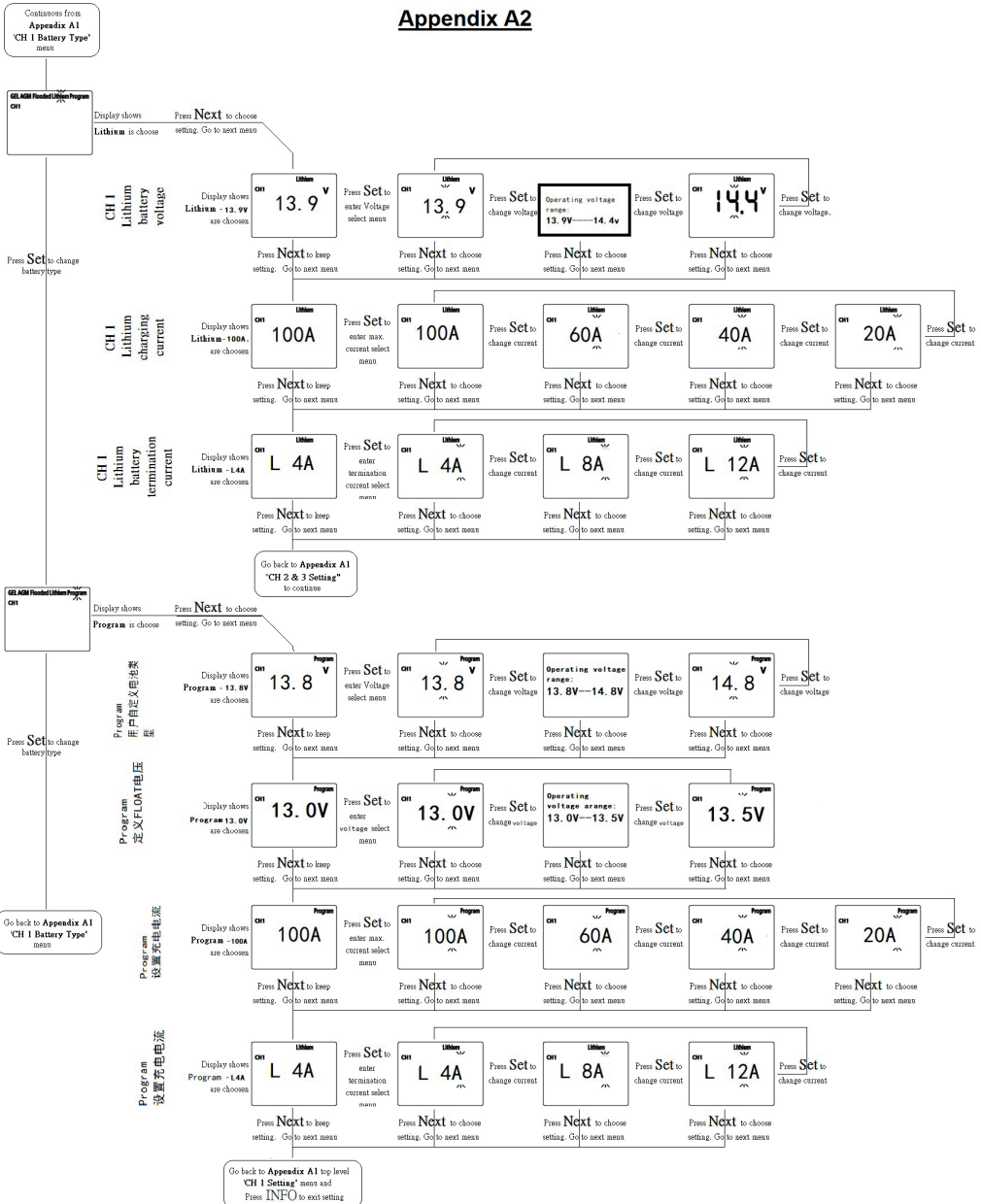

Appendix A3

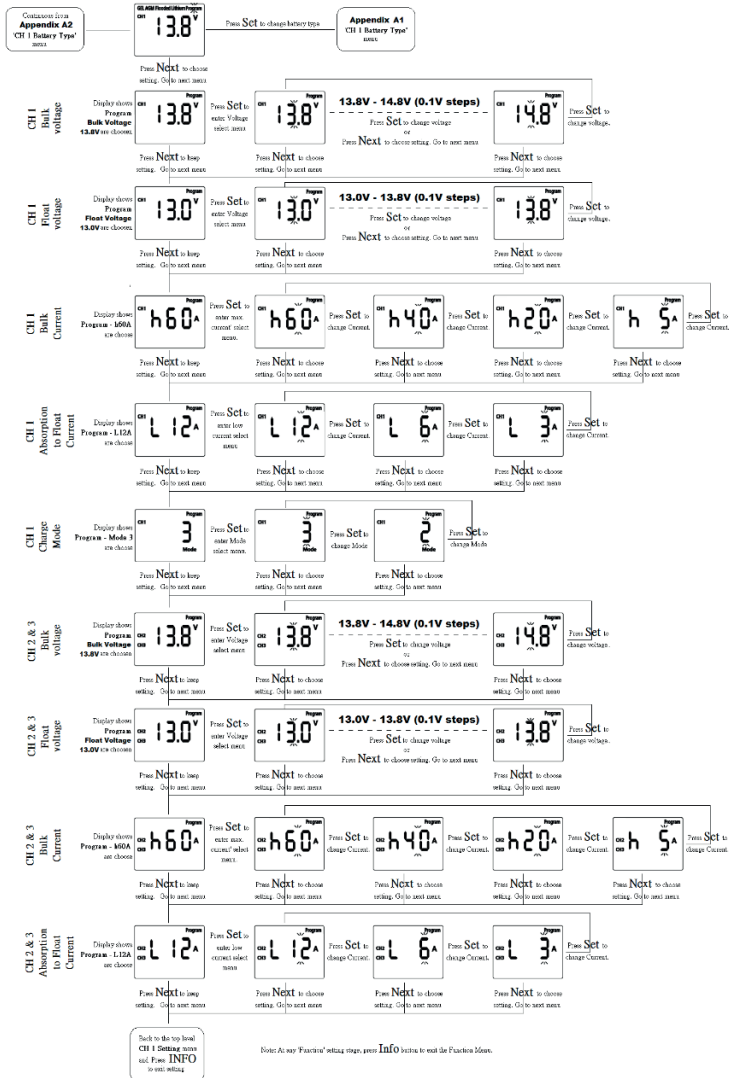

Note: The charging current setting values above are based on 60A model AC 1260. For other models, refer to the current chart on Appendix A2 and Section 5 'Procedure to set or view charger setting' for details.

WARNING: FIRE HAZARD!

When using the Program mode to set the battery charging parameters, please consult the battery manufacturer on all voltage and current settings. Using wrong setting to charge battery may overcharge and damage the battery, resulting in battery explosion and fire.

Proposed charging profile (2020) for Litium cell balancing

Based on the following setting:

- Lithium CV Voltage: 14.4V **B**
- Max charging current: 100A **E**
- Absorption to Float Current: 20A **F**
- Float Voltage: 13.8V **C**
- Recharge Voltage: 13.2V **D**

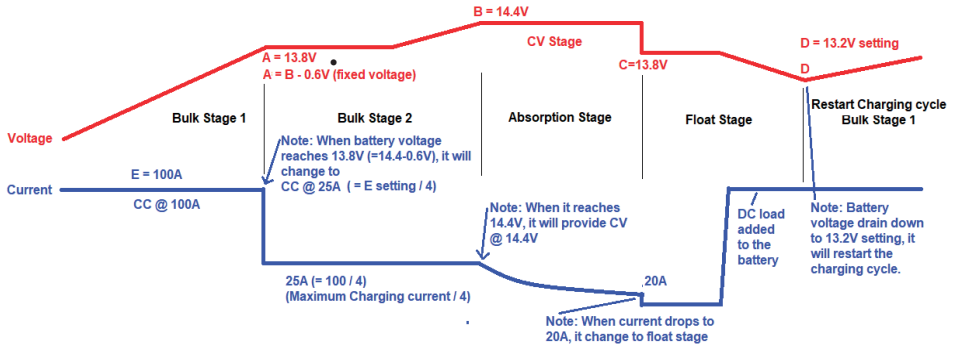



Enjoy Green Energy

WhisperPower BV

Kelvinlaan 82,
9207 JB Drachten
The Netherlands

www.whisperpower.com
sales@whisperpower.com

