

SOLARPOWER-HD™ Series

SOLARPOWER-HD™ Series - XUNZEL

High-Efficiency Photovoltaic Solar Panel
Ultra-Thin, Lightweight and Flexible

Product Overview

- Specially Designed to charge 12V and 24V batteries with maximum efficiency and optimum performance.
- High-Quality materials for all climatic conditions. IT WORKS!
- High-Quality Solar Cable included and pre-installed.
- Ready-to-Connect directly to the charger controller.
- Ultra-Thin (3mm), Lightweight and Flexible.
- Easy-to-install. Ready-to-connect. Stainless Steel Rings (Ø10 mm)
- Secure and easy wiring. Includes 3 meters pre-assembled 2-core, single solar cable.
- Completely Waterproof and Weatherproof junction box (IP67).
- High-Efficiency IBC all-back contact Monocrystalline Silicon Solar Photovoltaic Cells.
- Specially designed for 12V Off-Grid & Off-Shore Battery Charging Systems.
- Easy to connect in series for 24V systems.
- With high-efficiency bypass Schottky diodes included
- Higher power systems can be achieved easily connecting more strings in parallel (for more current) or series (for more voltage)
- New Design. All-Black Module
- Front-side junction box for a perfect assembly in flat surfaces
- High-performance and very reliable
- High Quality. 100% Flash and Electroluminescence-EL Tested
- With marine grade durability
- Ideal for marine, caravan, trucks, etc.



Available Models

SOLARPOWER-HD 50W-12V
SOLARPOWER-HD 110W-12V

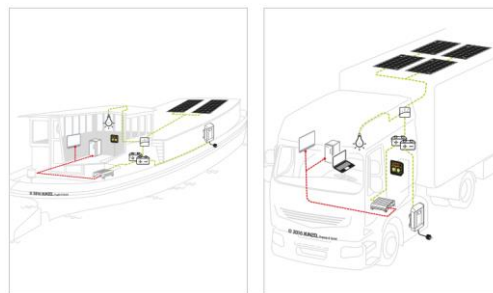

XU-2210105-MA | XUNZEL™ reserves the right to make changes and improvements without prior notice.

Industry Leading Technology for Off-Grid, Off-Shore and Backup Power Applications



© Copyright Xunzel. Information contained in this document is subject to change without notice.

SOLARPOWER-HD™ Series

Technical Specifications

Model	SOLARPOWER-HD-50W 12V	SOLARPOWER-HD-110W 12V
Maximum Power P_{max}	50W	110W
Nominal Voltage	12V	
Open Circuit Voltage V_{OC}	20.80V	21.90V
Maximum Power Point Voltage V_{MPP}	17.36V	18.56V
Short-Circuit Current I_{SC}	3.11A	6.32A
Maximum Power Point Current I_{MPP}	2.88A	5.97A
Maximum System Voltage SCII	45VDC	
Cells	IBC SUNPOWER Cell III-GEN 23.70%	
Dimensions (mm)	600 x 500 x 3 mm	1100 x 560 x 3 mm
Net Weight (kg)	1.35kg	2.50kg
Pre-assembled Cables	2-core cable (3 meters) Pre-cut 1.5cm 2x1,5mm ²	2-core cable (3 meters) Pre-cut 1.5cm 2x2,5mm ²
Grommets	4 pcs. Stainless Steel. Inner Ø10mm	6 pcs. Stainless Steel. Inner Ø10mm
Junction Box	IP67, Front-side	
Schottky Bypass Diode	2 pc	2 pcs
Operating Temperature	-40°C to +85°C	
Temperature Coefficient of Power	-0.30%/°C	
Temperature Coefficient of V_{OC}	-1.74mV/°C	
Temperature Coefficient of I_{SC}	2.20mA/°C	
Manufactured and Tested according to IEC 61215 / IEC 61730 Electrical data – Specifications at Standard Test Conditions (STC): 1000W/m ² solar irradiance, AM 1.5, 25 °C cell temperature.		



XU-2210105-MA | XUNZEL™ reserves the right to make changes and improvements without prior notice.

Industry Leading Technology for Off-Grid, Off-Shore and Backup Power Applications



SOLARPOWER-HD™ Series

Drawings

SOLARPOWER-HD-50W

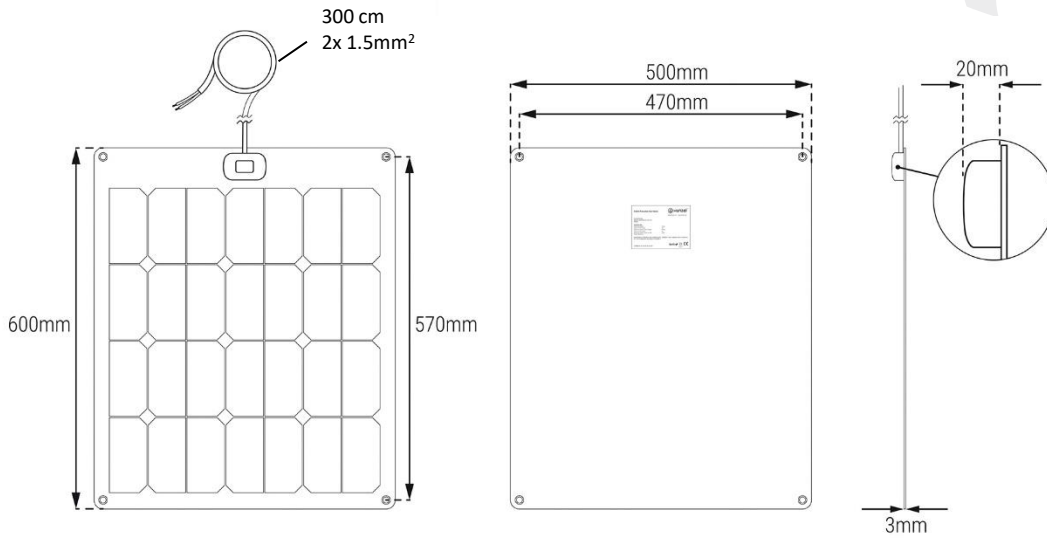

SOLARPOWER-HD-110W

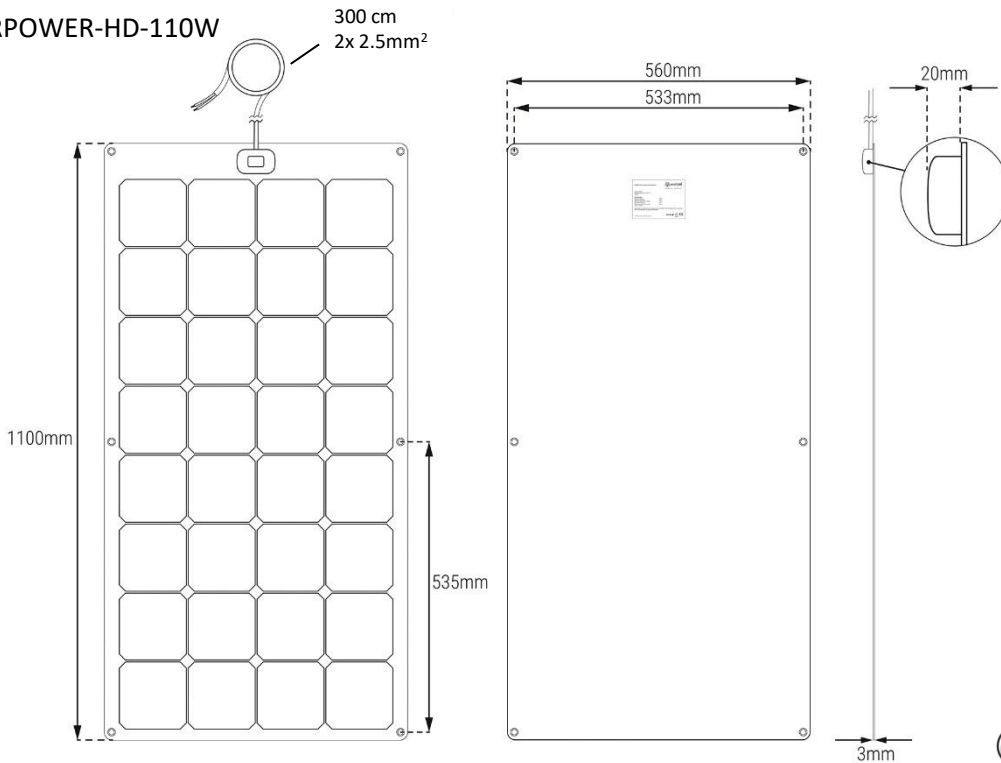

XU-2210105-MA | XUNZEL™ reserves the right to make changes and improvements without prior notice.



The design and all photos and drawings on these sheets are protected by law and may not be distributed or reproduced, in whole or in part, or published or used for any purpose without the express written consent of XUNZEL. XUNZEL - Xunzel is not responsible for any typographical errors. Specifications subject to change without notice.

Industry Leading Technology for Off-Grid, Off-Shore and Backup Power Applications



© Copyright Xunzel. Information contained in this document is subject to change without notice.